	TP SOUTHERN ODISHA DISTRIBUTION LIMITED, BERHAMPUR	
	TECHNICAL SPECIFICATION	
Document Title	SPECIFICATION FOR GI EARTHING PIPE (Medium)	
Document No.	ENG-MCH-055 A	Issue Date: 31.12.2023
Revision No.	01	Page 1 of 8
Prepared by:	Reviewed By:	Approved & Issued By:

CONTENTS

1. SCOPE
2. APPLICABLE STANDARDS
3. CLIMATIC CONDITIONS OF THE INSTALLATION
4. GENERAL TECHNICAL REQUIREMENTS
5. GENERAL CONSTRUCTIONS
6. MARKING
7. TESTS
8. TYPE TEST CERTIFICATES
9. PRE-DISPATCH INSPECTION
10. INSPECTION AFTER RECEIPT AT STORES
11. GUARANTEE
12. PACKING
13. TENDER SAMPLE
14. QUALITY CONTROL
15. TESTING FACILITIES
16. MANUFACTURING ACTIVITIES
17. SPARES, ACCESSORIES AND TOOLS
18. DRAWINGS AND DOCUMENTS
19. SCHEDULE "A" GUARANTEED TECHNICAL PARTICULARS
20. SCHEDULE "B" DEVIATIONS

	TP SOUTHERN ODISHA DISTRIBUTION LIMITED, BERHAMPUR	
	TECHNICAL SPECIFICATION	
Document Title	SPECIFICATION FOR GI EARTHING PIPE (Medium)	
Document No.	ENG-MCH-055 A	Issue Date: 31.12.2023
Revision No.	01	Page 2 of 8
Prepared by:	Reviewed By:	Approved & Issued By:

1. SCOPE:

The specification covers technical requirements of design, Manufacturing, testing, Inspection, supply and transportation of Medium type GI Earth Pipe Electrode. Scope also includes transportation & unloading at store / site.

2. APPLICABLE STANDARDS:

The equipment covered by this specification shall unless otherwise stated, be designed, manufactured and tested in accordance with the latest editions of the following Indian, International Standards and shall conform to the regulations of the local authorities:

IS 1239 (Part-1)	Specification of steel tubes, Tubular and other wrought steel fittings
IS 1239 (Part-2)	Specification of steel tubes, Tubular and other steel fittings
IS 10748	Hot- rolled steel strip for Welded Tubes and Pipes
IS: 228	Methods of Chemical analysis for steels
IS: 4759	Specification for Hot Dip Zinc Coating on structural steel and other allied products
IS: 4711	Methods for sampling of steel pipes, tubes, fittings
IS 3043	Code for practice of Earthing

3. CLIMATIC CONDITIONS OF THE INSTALLATION:

1	Maximum ambient temperature	50 deg C
2	Max. Daily average ambient temp	35 deg C
3	Min Ambient Temperature	0 deg C
4	Maximum Humidity	95%
5	Average Annual Rainfall	150cm
6	Average No. of rainy days per annum	120
7	Altitude above MSL not exceeding	1000m
8	Wind Pressure	300 Km/hr
9	Earthquakes of an intensity in horizontal direction	equivalent to seismic acceleration of 0.3g
10	Earthquakes of an intensity in vertical direction	equivalent to seismic acceleration of 0.15g (g being acceleration due to gravity)

	TP SOUTHERN ODISHA DISTRIBUTION LIMITED, BERHAMPUR	
	TECHNICAL SPECIFICATION	
Document Title	SPECIFICATION FOR GI EARTHING PIPE (Medium)	
Document No.	ENG-MCH-055 A	Issue Date: 31.12.2023
Revision No.	01	Page 3 of 8
Prepared by:	Reviewed By:	Approved & Issued By:

TPSODL service area has heavy saline conditions along the coast and High cyclonic Intensity winds with speed upto 300 Kmph. The atmosphere is generally laden with mild acid and dust in suspension during the dry months and is subjected to fog in cold months.

4. GENERAL TECHNICAL REQUIREMENTS:

SL. No	TECHNICAL PARTICULAR	Desired Value	
1	Diameter of earthing Pipe	100 mm Dia.	40 mm Dia.
2	Standard	IS 1239	IS 1239
3	Material	GI Pipe	GI Pipe
4	Make	JINDAL /TATA	JINDAL /TATA
5	Class	Medium	Medium
6	Outdoor diameter	113.1 mm min. to 115 mm max.	47.9 mm min. to 48.8 mm max.
7	Wall thickness	4.5 mm	3.2 mm
8	% of Elongation	20	20
9	Tensile strength	320 N/mm ²	320 N/mm ²
10	Length of pipe earthing	3000 mm	3000 mm
11	Dimensions of holes	12 mm	12 mm
12	Tolerance on dimensions/weight	+/-5 %	+/-5 %
13	Galvanizing shall confirm	IS: 2633, IS: 2629	IS: 2633, IS: 2629
14	Weight	12.2 kg/mtr.	3.56 kg/mtr.
15	Dimension of clamp	50 x 6 GI flat	50 x 6 GI flat

Note: - For design and other parameter refer to the drawing on page No: -7.

5. GENERAL CONSTRUCTION:

For welded and seamless plain end steel tubes intended for different use in electricity distribution utility shall comply IS 1239 (Part-1). Plain ends of the tubes are cleanly finished by normal deburring process. For tubes of any thickness the minimum mass of Zinc Coating is 360 gm Sq.mtr. The Zinc coating on the tube shall be uniform and tested in accordance with IS 4736. The welded tubes shall be manufactured from hot rolled steel strip for welded tubes and pipes confirming to IS 10748. Pipe shall be strictly from approved vendors i.e. TATA/JINDAL. The hot dip galvanization shall be done only after the all fabrication and welding done. Zinc electroplated/painted material will not be accepted. The nut bolt and washer s provided shall be as per the relevant IS. Chemical composition for GI earth pipe are in below:

Carbon: 0.20% (max.)

Manganese: 1.30% (max.)

Phosphorus: 0.04% (max.)

	TP SOUTHERN ODISHA DISTRIBUTION LIMITED, BERHAMPUR	
	TECHNICAL SPECIFICATION	
Document Title	SPECIFICATION FOR GI EARTHING PIPE (Medium)	
Document No.	ENG-MCH-055 A	Issue Date: 31.12.2023
Revision No.	01	Page 4 of 8
Prepared by:	Reviewed By:	Approved & Issued By:

Sulphur: 0.04% (max.)

6. MARKING:

The unit shall be appropriately marked as

- a) TPSODL
- b) Manufacture's name or trademark
- c) PO No.
- d) Year of Manufacturing

7. TESTS:

The bidder shall be required to submit complete set of the following test reports along with the offer:-

7.1 ACCEPTANCE TESTS

- i) Visual Inspection
- ii) Verification of Dimensions
- iii) Tensile Strength
- iv) Bend Test
- v) Hot Dip galvanizing
- vi) Determination of mass of Zinc coating on Zinc coated iron and steel

7.2 ROUTINE TESTS

Same as Acceptance Test

7.3 TYPE TESTS

- i) Visual Inspection
- ii) Verification of Dimensions
- iii) Tensile Strength
- iv) Bend Test
- v) Flattening test (dia.>50mm)
- vi) Hot Dip galvanizing
- vii) Determination of mass of Zinc coating on Zinc coated iron and steel

8. TYPE TEST CERTIFICATES:

The Bidder shall furnish the type test certificates for the tests as mentioned above as per the corresponding standards. All the tests shall be conducted at **CPRI / ERDA / Other Government Labs** as per relevant IS. Type tests should have been conducted during the period not exceeding

	TP SOUTHERN ODISHA DISTRIBUTION LIMITED, BERHAMPUR	
	TECHNICAL SPECIFICATION	
Document Title	SPECIFICATION FOR GI EARTHING PIPE (Medium)	
Document No.	ENG-MCH-055 A	Issue Date: 31.12.2023
Revision No.	01	Page 5 of 8
Prepared by:	Reviewed By:	Approved & Issued By:

5 years from the date of opening the bid. In the event of any discrepancy in the test reports, i.e. any test report not acceptable, same shall be carried out without any cost implication to TPSODL.

9. PRE-DISPATCH INSPECTION:

The material shall be subject to inspection by a duly authorized representative of the TPSODL. Inspection may be made at any stage of manufacture at the discretion of the purchaser and the equipment, if found unsatisfactory as to workmanship or material, the same is liable to rejection. Bidder shall grant free access to the places of manufacture to TPSODL's representatives at all times when the work is in progress. Inspection by the TPSODL or its authorized representatives shall not relieve the bidder of his obligation of furnishing equipment in accordance with the specifications. Material shall be dispatched after specific MDCC (Material Dispatch Clearance Certificate) is issued by TPSODL.

Following documents shall be sent along with material.

- a) Test reports
- b) MDCC issued by TPSODL
- c) TPSODL Invoice in duplicate
- d) Packing list
- e) Drawings & catalogue
- f) Guarantee / Warrantee card
- g) Delivery Challan
- h) Other Documents (as applicable)

10. INSPECTION AFTER RECEIPT AT STORE:

The material received at TPSODL, Odisha store will be inspected for acceptance and shall be liable for rejection, if found different from the reports of the pre-dispatch inspection and one copy of the report shall be sent to Engineering department.

11. GUARANTEE:

Bidder shall stand guarantee towards design, materials, workmanship & quality of process/ manufacturing of items under the contract for due and intended performance of the same, as an integrated product delivered under this contract. In the event any defect is found by the Company up to a period of 18 months from the date of commissioning or 24 months from the date of last supplies made under the contract, whichever is earlier, supplier shall be liable to undertake to replace/rectify such defects at his own costs. within mutually agreed timeframe, and to the entire satisfaction of the Company, failing which the Company will be at liberty to get it replaced/rectified at supplier's risks and costs and recover all such expenses plus the Company's own charges (@

	TP SOUTHERN ODISHA DISTRIBUTION LIMITED, BERHAMPUR	
	TECHNICAL SPECIFICATION	
Document Title	SPECIFICATION FOR GI EARTHING PIPE (Medium)	
Document No.	ENG-MCH-055 A	Issue Date: 31.12.2023
Revision No.	01	Page 6 of 8
Prepared by:	Reviewed By:	Approved & Issued By:

20% of expenses incurred), from the supplier or from the “Security cum Performance Deposit” as the case may be.

12. PACKING:

Supplier shall ensure that all material covered by this specification shall be prepared for rail/road transport (local equipment) and be packed in such a manner as to protect it from damage in transit. The bidder shall provide instructions regarding handling and storage precautions to be taken at site.

13. TENDER SAMPLE:

Not Applicable

14. QUALITY CONTROL:

The bidder shall submit QAP indicating the various stages of inspection, the tests and checks which will be carried out on the material of construction, components during manufacture and bought out items and fully assembled component and equipment after finishing. As part of the plan, a schedule for stage and final inspection within the parameters of the delivery schedule shall be furnished. The Purchaser's engineer or its nominated representative shall have free access to the manufacturer's/sub-supplier's works to carry out inspections.

15. TESTING FACILITIES:

Supplier/ Manufacturer shall have adequate in-house testing facilities for carrying out all routine tests & acceptance tests as per relevant Indian standards.

16. MANUFACTURING FACILITIES:

The successful bidder shall submit the bar chart for various manufacturing activities clearly elaborating each stage, with quantity. This bar chart should be in line with the Quality assurance plan submitted with the offer.

17. SPARES, ACCESSORIES AND TOOLS

Not applicable.

18. DRAWINGS AND DOCUMENTS:

Following drawings and documents shall be submitted in line with the requirement of Tender specifications:

- a) Completely filled in Schedule “A” Guaranteed Technical Particulars & Schedule “B” Deviations
- b) Work Experience details
- c) Type test certificates
- d) Drawing 1 set of Hard Copy & Soft copy PDF File containing complete information about

TPSODL	TP SOUTHERN ODISHA DISTRIBUTION LIMITED, BERHAMPUR	
	TECHNICAL SPECIFICATION	
Document Title	SPECIFICATION FOR GI EARTHING PIPE (Medium)	
Document No.	ENG-MCH-055 A	Issue Date: 31.12.2023
Revision No.	01	Page 7 of 8
Prepared by:	Reviewed By:	Approved & Issued By:

manufacturing

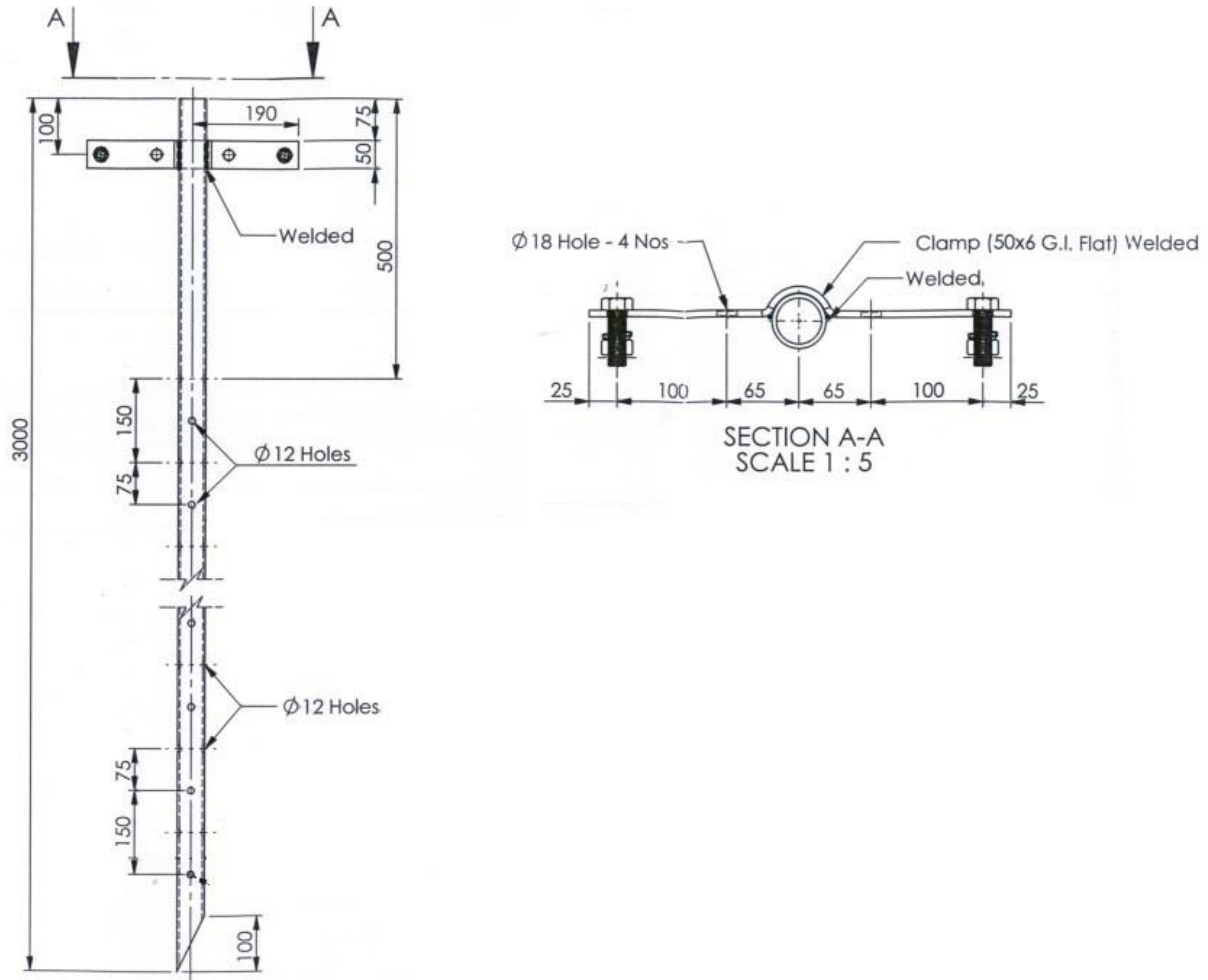

NOTE: - The indicative drawing is for tender purpose only.

19. SCHEDULE- "A" GUARANTEED TECHNICAL PARTICULARS: -

SL. No	TECHNICAL PARTICULAR	TO BE FURNISHED BY THE BIDDER		
1	Diameter of earthing Pipe	40 mm dia	50 mm dia	100 mm dia
2	Standard			
3	Material			
4	Make			
5	Class			
6	Outdoor diameter			
7	Wall thickness			
8	% of Elongation			
9	Tensile strength			
10	Length of pipe earthing			
11	Dimensions of holes			

	TP SOUTHERN ODISHA DISTRIBUTION LIMITED, BERHAMPUR	
	TECHNICAL SPECIFICATION	
Document Title	SPECIFICATION FOR GI EARTHING PIPE (Medium)	
Document No.	ENG-MCH-055 A	Issue Date: 31.12.2023
Revision No.	01	Page 8 of 8
Prepared by:	Reviewed By:	Approved & Issued By:

12	Tolerance on dimensions/weight			
13	Galvanizing shall confirm			
14	Weight			
15	Dimension of clamp			

20. SCHEDULE "B" DEVIATIONS:

(TO BE ENCLOSED WITH TECHNICAL BID)

All deviations from this specification shall be set out by the Bidders, clause by Clause in this schedule. Unless specifically mentioned in this Schedule, the tender shall be deemed to confirm the purchaser's specifications:

SL. No	Clause No.	Details of deviation with justifications

We confirm that there are no deviations apart from those detailed above.

Seal of the Company:

Signature

Designation